



# Copper Anti-Seize Tape

## Mill-Rose Copper Anti-Seize Tape

*A copper impregnated PTFE thread sealing tape.*

*A clean and efficient alternative to anti-seize compounds*

### Description

Mill-Rose Copper Anti-Seize Tape is a unique product designed to permit the easy assembly and disassembly of threaded components. It takes the place of messy and potentially contaminating anti-seize compounds.

Mill-Rose Copper Anti-Seize Tape is manufactured from a copper filled PTFE resin. The PTFE provides excellent lubricity while the copper flakes act as slide or bearing plates between the two mating surfaces. Thus, the tape helps prevent galling during assembly and disassembly of components.

When wrapped around a thread, Mill-Rose Copper Anti-Seize Tape seals it from corrosive substances or any dirt or grit likely to cause seizure.

Mill-Rose Copper Anti-Seize Tape also prevents components from vibrating loose.

### Characteristics

- Resistant to a broad range of chemicals
- Compatible with a wide range of metals
- Will not rub, scuff or squeegie off
- Effective across a broad range of temperatures
- Clean
- No-waste
- Non-toxic
- Non-flammable
- Compact

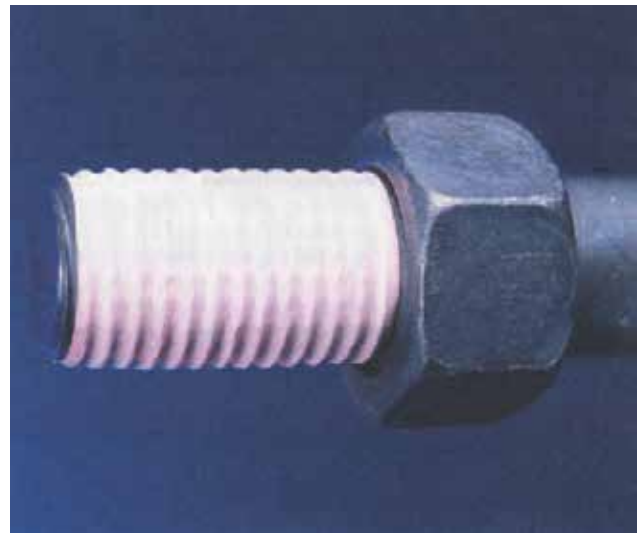

### Applications

Mill-Rose Copper Anti-Seize Tape can be applied to any threaded component made from the following metals: galvanized steel, steel, iron, brass, copper, aluminum, titanium and magnesium. However, it is not recommended for stainless steel.

For stainless steel components, Mill-Rose Nickel Anti-Seize Tape is recommended. It is also resistance to strong alkaline solutions, most chemical and acid va-

pors, road salt, steam, salt and iodized water. Consult precautions before use.

For a more detailed list of chemicals compatible with Copper Anti-Seize Tape, contact Mill-Rose.



**7310 Corporate Blvd., Mentor, OH 44060**

**To order call toll-free: (800) 321-3598 or Fax (440) 255-1072**

**Visit our web site at [www.CleanFit.com](http://www.CleanFit.com) • E-mail: [info@CleanFit.com](mailto:info@CleanFit.com)**



# Copper Anti-Seize Tape

## Mill-Rose Copper Anti-Seize Tape

*A copper impregnated PTFE thread sealing tape.*

*A clean and efficient alternative to anti-seize compounds*

### Specifications

Composition	90% PTFE / 10% copper
Color	Copper
Thickness	0.0045" +/-10% (0.115mm +/-10%)
Density, apparent	1.6g/cm <sup>3</sup> +/- 10%
Elongation	50%
Temperature range	-450°F to +500°F (-268°C to +260°C) PTFE is completely stable up to +500° F or +260°C. Decomposition will occur on contact with naked flames. Upon decomposition, the remaining copper powder will assist disassembly. Copper flake will melt at 1,984° F or 1,084° C.
Tensile Strength	10-12N/mm <sup>2</sup>

### Instructions

#### Components up to 1 1/2" (38mm) diameter

1. Use 1/2" (12mm) wide tape.
2. Clean the male and female threads thoroughly.
3. Wrap the tape around the male thread. Take care to keep the tape under tension as you are wrapping so the tape molds itself into the root of the thread.
4. Make sure that you wrap with the thread.

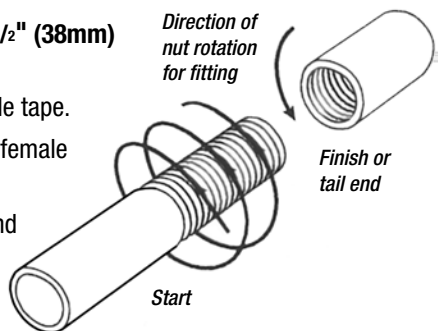

5. Overlap the tape 50% on each wrap.
6. Cover the entire threaded portion of the component with tape.

#### Components above 1 1/2" (38mm) in diameter.

1. Use 3/4" (19mm) wide tape.
2. Follow the directions given above.

**Note.** Mill-Rose Copper Anti-Seize Tape is approximately 0.0045" (0.115mm) thick. Therefore, when applied as directed, it will add approximately 0.018 (0.46mm) to the diameter of the threaded portion of the component. Ensure that this is within tolerance. Where Mill-Rose Copper Anti-Seize Tape cannot be used, Copper Anti-Seize Compound is recommended.

### Precautions

**Note.** Keep Mill-Rose Copper Anti-Seize Tape clean. Replace the clip on the spool after use. Store in a clean place. Mill-Rose Copper Anti-Seize Tape is manufactured predominantly from PTFE resin. PTFE is virtually chemically resistant to all medias, however, there are a few exceptions. Alkali metals such as elemental sodium, potassium and lithium are to be avoided. These alkali metals remove fluorine from the polymer molecule. Extremely potent oxidizers such as fluorine (F<sub>2</sub>) and related compounds (e.g., chlorine trifluoride (ClF<sub>3</sub>)) can be handled by PTFE, but only with great care. Since fluorine is absorbed into the resin, the mixture becomes sensitive to a source of ignition such as impact. Other

media to avoid are 80% NaOH or KOH, metal hydrides such as boranes (e.g., B<sub>2</sub>H<sub>6</sub>), aluminum chloride, ammonia (NH<sub>3</sub>), certain amines (R-NH<sub>2</sub>), imines (R-NH) and 70% nitric acid at temperatures near the suggested service level. Mill-Rose Copper Anti-Seize Tape also contains copper powder. Acids will react with the copper on the surface of the tape. For applications where the presence of copper is prohibited, use Mill-Rose Nickel Anti-Seize Tape. Mill-Rose Copper Anti-Seize Tape is not designed specifically to be thread sealant. However, it will seal threaded pipes up to 500°F (260°C).

#### **However, do not use Mill-Rose Copper Anti-Seize Tape to seal lines carrying oxygen!**

For oxygen service, Mill-Rose Green Oxygen Tape is recommended. For further safety details, consult the Material Safety Data Sheet .

### Limited Liability

The information presented is in good faith, but no warranty is given nor are results guaranteed. Since we have no control over the physical conditions surrounding the application of information contained herein, Mill-Rose disclaims any liability for untoward results.

**7310 Corporate Blvd., Mentor, OH 44060**

**To order call toll-free: (800) 321-3598 or Fax (440) 255-1072**

**Visit our web site at [www.CleanFit.com](http://www.CleanFit.com) • E-mail: [info@CleanFit.com](mailto:info@CleanFit.com)**